

6 5 4 3 2 1

D

C

B

A

D

C

B

A

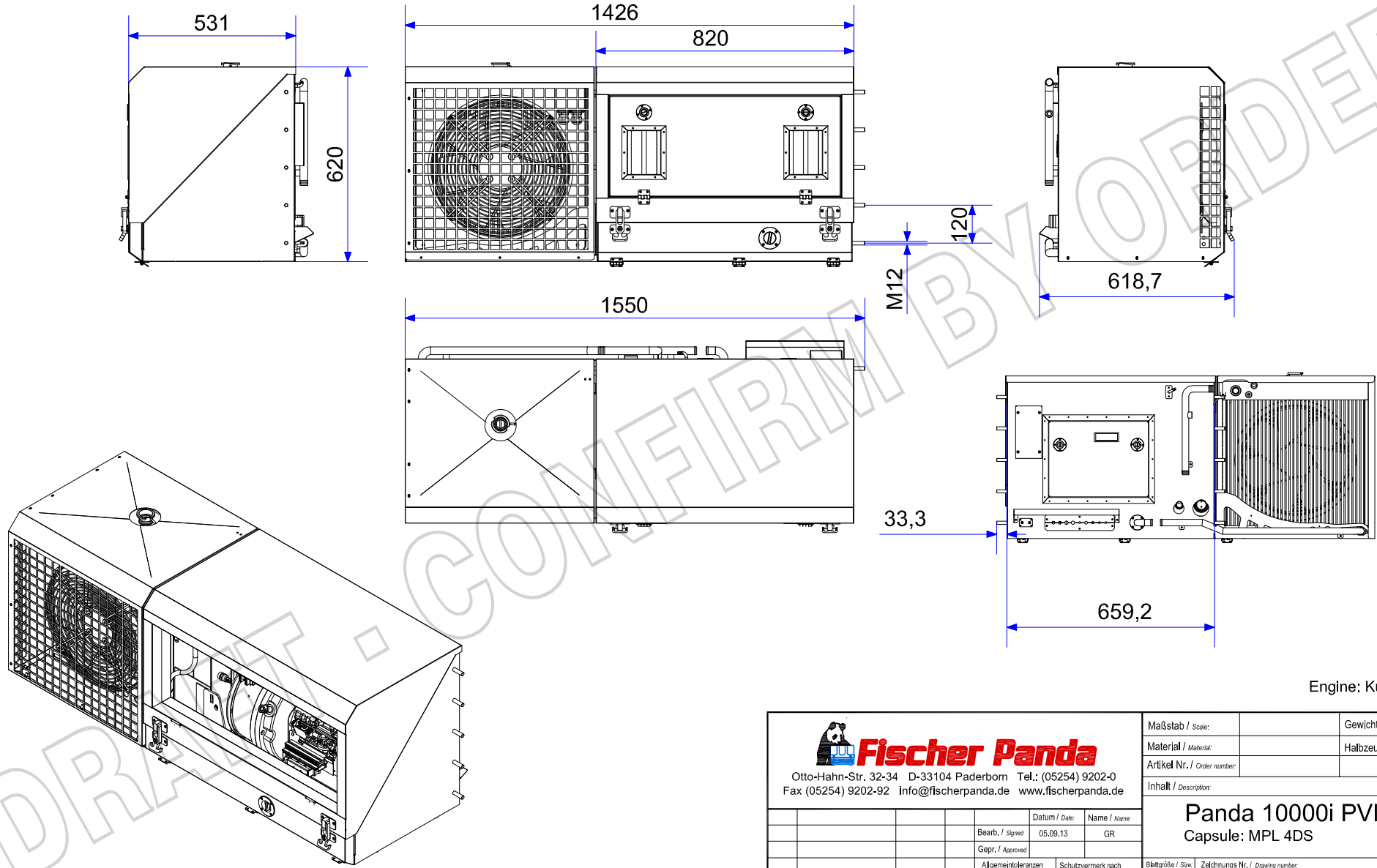

Engine: Kubota Z602

 Otto-Hahn-Str. 32-34 D-33104 Paderborn Tel.: (05254) 9202-0 Fax (05254) 9202-92 info@fischerpanda.de www.fischerpanda.de		Maßstab / Scale:		Gewicht / Weight:	
		Material / Material:		Halbzeug / Semi-finished products:	
Artikel Nr. / Order number:					
Inhalt / Description:					
<b>Panda 10000i PVK-UK</b> Capsule: MPL 4DS					
Zust.		Änderungen / Modifications		Datum / Date	
Baarb. / Signed		Datum / Date		Name / Name:	
		05.09.13		GR	
Gepr. / Approved					
Allgemeintoleranzen nach DIN ISO 2768-mK General tolerances according to DIN ISO 2768-mK		Schutzvermerk nach DIN ISO 16016 beachten! Observe protection notice in accordance with DIN ISO 16016			
Blattgröße / Size:		Zeichnungs Nr. / Drawing number:		Blatt / Sheet	
WG.1398e00				1 1	
Ersatz für / Replacement for:				Ersetzt durch / Replaced by:	

6 5 4 3 2 1