

## Case Study

# Empowering Education: Sustainable Power Solutions for RHA's Mobile Exhibition Project

Owlvue, a young up-and-coming UK company, renowned for their expertise in vehicle safety solutions, crafted the new RHA's mobile exhibition and training unit. This innovative project aims to enhance safety and efficiency for road transport and logistics operators as well as contribute to the education and education of the younger generation of drivers.



What sets Mastervolt apart in this case is the greener and more sustainable approach.

The Mastervolt lithium batteries not only provide a robust power source but also make the RHA mobile exhibition unit environmentally friendly and utilise renewable energy. This means it can operate seamlessly in low-emission zones, including bustling cities like London and Bristol.

The 6kW battery, combined with solar panels on the roof, greatly extends the operational hours, adding immense value to the educational programmes of RHA.



**Fischer Panda**  
UK

**POWER  
SOLUTIONS**

Providing complete system solutions for the marine, vehicle and defence sectors.

Fischer Panda generators and e-propulsion; Parker watermakers; Dometic air-conditioning; Mastervolt power electronics; CZone digital switching; Autoclima vehicle air-conditioning; Autoterm diesel heaters; Clayton power.

# Case Study

## Empowering Education: Sustainable Power Solutions for RHA's Mobile Exhibition Project

### About the companies

RHA (Road Haulage Association): As the trade association of choice for hire and reward road transport and logistics operators, RHA represents the interests of UK commercial vehicle operators, including HGVs, coaches, and vans.

Owlvue: Leaders in supplying and fitting vehicle safety aids, Owlvue specialises in dash cameras, reverse cameras, multi-camera systems, remote vehicle tracking, telematics, blind spot detection, and alarms. Their solutions cater to various vehicles across diverse industries, overcoming unique challenges.

### Application Diagram

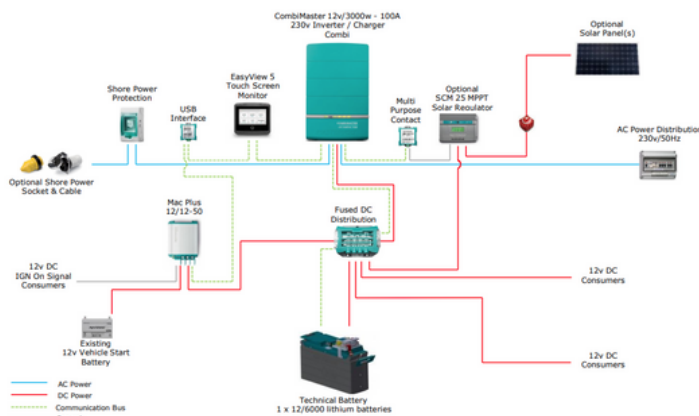

### System components

Mastervolt products that contributed to the success of this project:

- Mastervolt MLI Ultra 12/6000: A powerful lithium-ion battery providing efficient energy storage.
- Combimaster 12/3000-100-230 V: A versatile and compact inverter-charger ensuring a seamless power supply.
- MAC Plus 12/12-50: An advanced DC-DC converter for optimal power distribution.
- Solar Charge Controllers SCM25 MPPT: Harnessing solar energy efficiently for sustainable power.

### Technical expertise and collaboration

This collaboration exemplifies the power of innovation and partnership. Fischer Panda UK, Owlvue, and RHA together have set a new benchmark for safety and efficiency in the road transport industry. We are proud to be part of this transformative journey and look forward to more such collaborations that drive positive change!



Providing complete system solutions for the marine, vehicle and defence sectors.

Fischer Panda generators and e-propulsion; Parker watermakers; Dometic air-conditioning; Mastervolt power electronics; CZone digital switching; Autoclima vehicle air-conditioning; Autoterm diesel heaters; Clayton power.