

CLIMATE

TURBO SELF-CONTAINED A/C

Designed from the inside out with multiple patented innovations, the Turbo continues to evolve with even more enhanced design features and options.

INCREASED EFFICIENCY
SAVES POWER

MORE COOLING
HIGHER CAPACITY

DUAL FREQUENCY
ACCEPTS 50 or 60 Hz

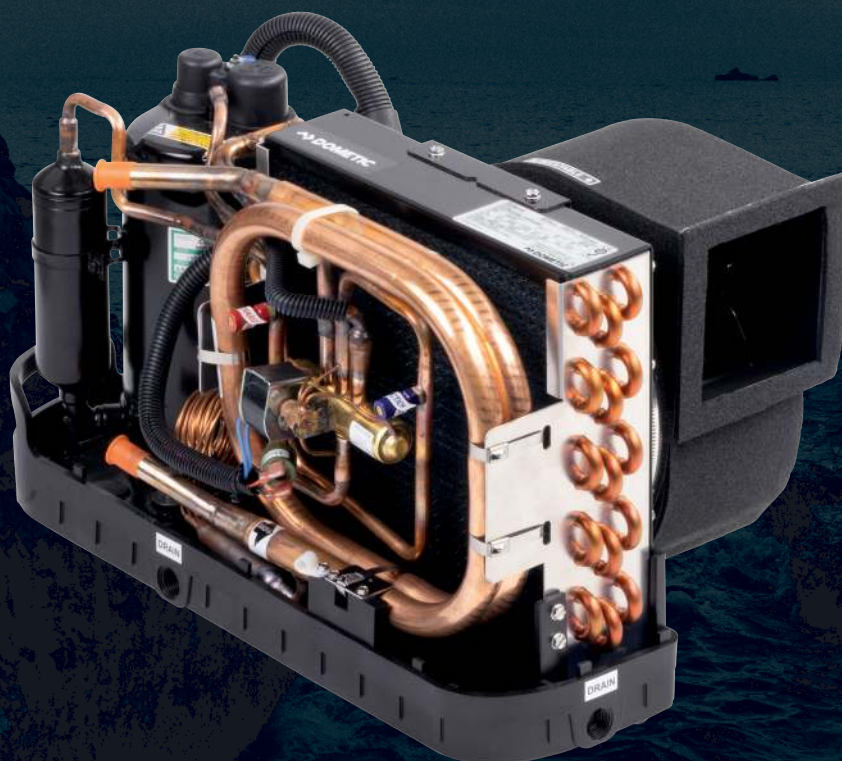

115V/50/60Hz
230V/50/60Hz



6,000 - 16,000 BTU

Mobile living made easy.

 **DOMETIC**

REVOLUTIONARY INNOVATION



The Turbo series completely revolutionized self-contained boat air conditioning with patented innovations in system design. Energy efficient, high capacity, and compact, the Turbo is a tough but elegant solution that keeps getting better.

Technicians often encounter a tight squeeze when installing a new A/C unit on a boat, but the Turbo was designed to make installation fast and simple.

BENEFITS OF A TURBO SYSTEM

- Operates at 50 or 60Hz; lower voltage units will run 100-120 volts 50/60Hz and higher voltage units will run 200-240 volts 50/60Hz
- Special coating on the condenser coil helps shed water more quickly which minimizes corrosion
- Channels in drain pan guide water directly to multiple drain locations, regardless of boat's heeling angle
- Rotate the blower up to 270° to find the perfect ducting angle using a single adjustment screw
- Critical components are easily accessible for simplified servicing

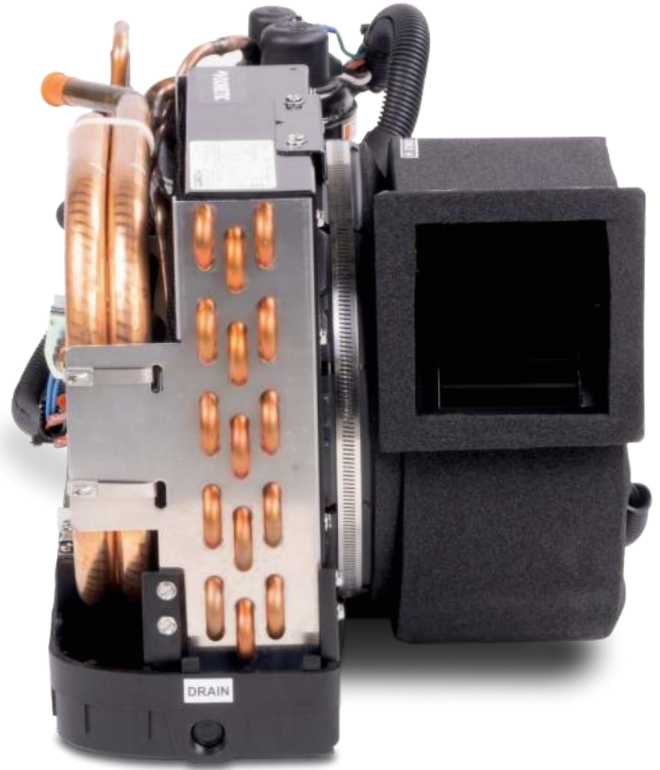

QUIET OPERATION

Multiple cushioned vibration mounts inserted into the bottom of the molded drain pan, and specially designed mounting clips isolate the unit's vibration from the mounting surface. This minimizes operating noise. For an even quieter system, add the optional compressor sound shield.

RAPID DRAINAGE

The rust-free molded composite drain pan has three drains for rapid removal of condensate water. Channels built into the pan guide water directly to the drain locations, regardless of which way the boat is heeling.

COMPACT SIZE

At the same time the Turbo was designed to be more powerful, it was also designed to be smaller in height and depth so it can easily fit into more spaces. There is no blower-motor overhang, and the drain pan has a small footprint.

SPECIFICATIONS FOR TURBO SERIES SELF-CONTAINED A/C



Model ¹	DTG6			DTG8			DTG10			DTG12			DTG16		
Capacity (BTU/h)	6000			8000			10000			12000			16000		
Voltage (VAC)	115	230	230	115	230	230	115	230	230	115	230	230	115	230	230
Cycle (Hz) /Phase (Ph)	60/1	60/1	50/1	60/1	60/1	50/1	60/1	60/1	50/1	60/1	60/1	50/1	60/1	60/1	50/1
Full Load Amps (FLA) Cool (A)	4.4	2.0	1.9	5.5	2.9	3.2	6.3	3.2	3.1	7.7	3.8	4.4	10.3	5.5	4.7
Full Load Amps (FLA) Heat (A)	5.8	2.6	2.4	6.9	3.7	3.8	8.1	4.1	3.9	10.2	5.0	5.2	13.4	7.0	6.0
Full Load Amps (FLA) Blower (A)	0.8	0.4	0.4	1.3	0.7	0.8	1.1	0.6	0.5	1.1	0.6	0.5	1.6	0.8	0.6
Locked Rotor Amps (LRA)	25.5	10.0	10.9	28	15.0	16.8	41.5	21.0	24.4	50.5	26.7	28.4	61.0	26.9	29.4
Max. Circuit Breaker (A)	18	9	8	21	12	12	29	15	15	35	19	18	44	23	21
Min. Circuit Ampacity (A)	10	5	4	12	7	7	17	9	8	20	11	10	25	13	12
Refrigerant Type	410A			410A			410A			410A			410A		
Min. Height (in/cm)	11.4/29.0			11.6/29.5			12.2/31.0			12.2/31.0			13.3/33.8		
Max Width	17.8/45.2			17.8/45.2			20.4/51.8			20.4/51.8			21.5/54.6		
Max Depth	10.7/27.2			10.7/27.2			12.4/31.5			12.4/31.5			13.3/33.8		
Min. Duct Size Dia.(in/cm)	4/10.16			5/12.7			6/15.2			6/15.2			13.3/33.8		
Min. Supply Air Grille (sq in/cm)	32/206			48/310			60/387			70/452			80/516		
Min. Return Air Grille (sq in/cm)	64/413			80/516			100/645			130/839			160/1032		
Net Weight (lbs/kg)	38.0/17.2	38.0/17.2		41.0/18.6	43.0/19.5		53.0/24.0	52.0/23.6		53.0/24.0	53.0/24.0		57.0/25.9	58.0/26.3	
Gross Weight (lbs/kg)	44.0/20.0	44.0/20.0		48.0/21.8	50.0/22.7		62.0/28.1	61.0/27.7		62.0/28.1	62.0/28.1		66.0/29.9	67.0/30.4	

1) BTU and electrical data are based on a 45 degree F/7.2 degree C evaporator and 100 degree F/37.8 degree C condenser in cool mode, and a 45 F/7.2 C evaporator and 130 degree F/54.4 degree C condenser in heat.
2) Electric box is remote mounted up to 34" (86cm) away from compressor. E-box dimensions are 2.7" (6.9cm) x 6.5" (16.5cm) x 8.8" (22.4cm).

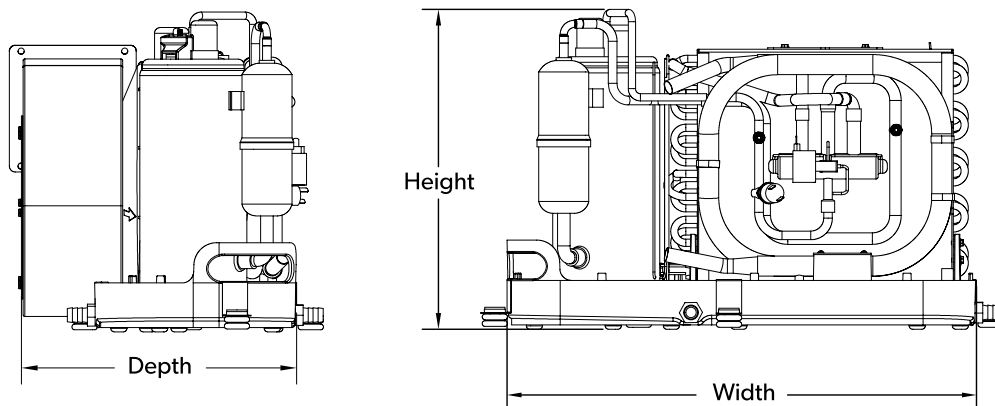

TURBO SELF-CONTAINED A/C OPTIONAL EQUIPMENT

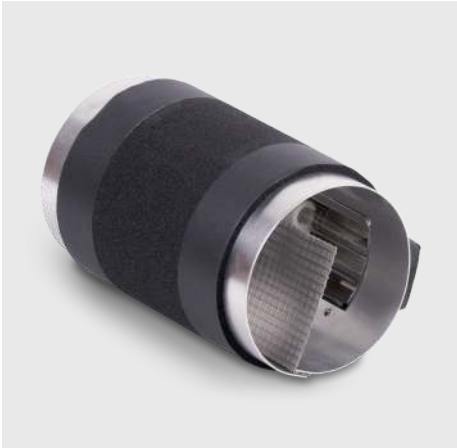

BREATHE CLEANER AIR

The In-Duct Breathe Easy™ Air Purifier eliminates odors and contaminants from the air you breathe. It reduces bacteria, fungi, pollen, and volatile organic compounds (VOCs) by up to 99.9%. Operating silently within the ducting, it purifies cabin air using Photocatalytic Nano-Mesh Technology with UV light. As the A/C's blower circulates air through the cabin, the air is further purified with every pass.



DIRECT RETURN-AIR PATH

Don't have the optimum location in your cabin to install a Turbo in the return air path? Increase installation options with a return plenum that ducts return air directly to the Turbo even if it cannot be installed by the return grille.



ELIMINATE STARTUP SPIKES

Buffer the compressor's startup power demand by smoothing out the short, sudden amp drain on the generator. The Smart Start eases the strain on the generator and starts the compressor more gently, meaning lights and other electrical appliances won't flicker and falter.



REDUCE OPERATING NOISE

Surround the compressor with a custom-molded sound shield to make a quiet system even quieter. Use when maximum noise mitigation is desired.

