

6 5 4 3 2 1

D

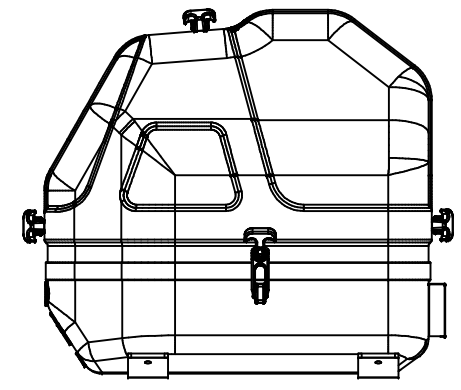
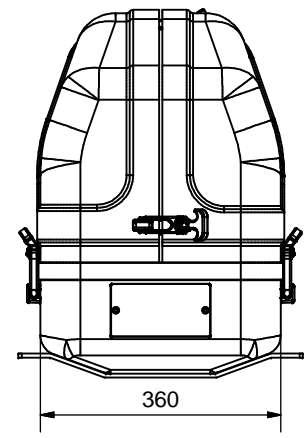
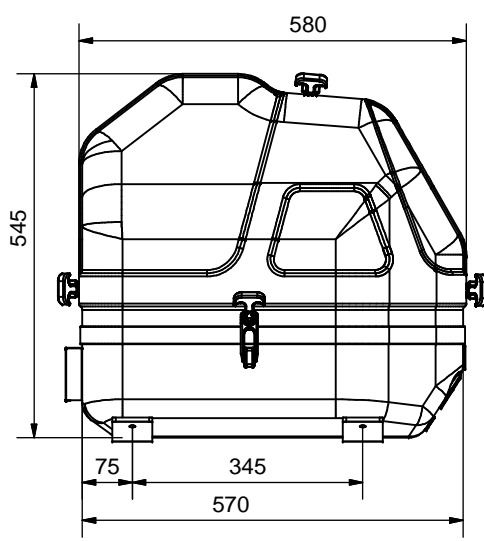
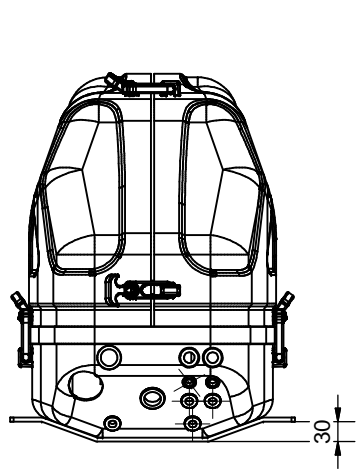

C

B

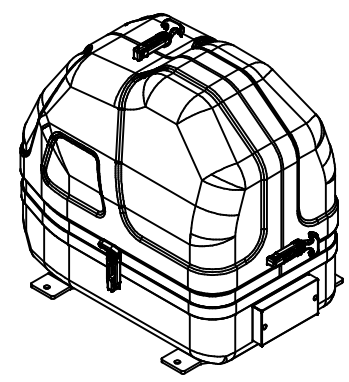
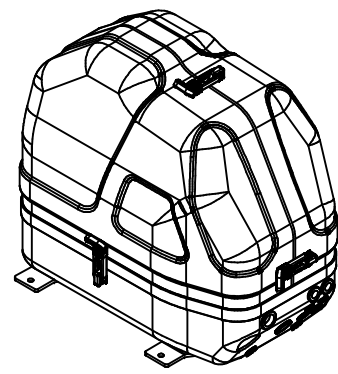
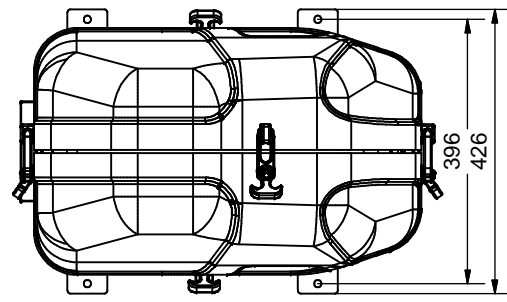

D

C

B

Technische Daten u. Hauptabmessungen technical data and main dimensions	
Kapsel/ capsule	GFK
Motor/ engine	Farymann 18W430
Schalldämmung/ sound insulation	3D
Länge/ length *)	580mm
Breite/ width *)	360mm
Höhe/ height *)	545mm
Gewicht/ weight	93kg
Verkaufsunterlagen, Änderungen vorbehalten sales document, subject to change without notice	

\*) Abmessungen des Schalldämmgehäuses, überstehende Teile wie Verschlüsse, Fittinge etc. sind nicht berücksichtigt  
\*) dimensions of the sound shield housing only, components fitted to the housing as fasteners, fittings etc are not included

 <b>Fischer Panda</b> Otto-Hahn-Str. 32-34 D-33104 Paderborn Tel.: (05254) 9202-0 Fax (05254) 9020-550 info@fischerpanda.de www.fischerpanda.de				Verkaufsunterlagen/ Sales Dokument	
				Artikel Nr.:	
				Generator kplt P4000s GFK 3D	
				Model Nr.:	
				FP1-009007 -	
				2D Zeichnungs Nr.:	
				FP1-010685	
				Blatt 1	
				Ersatz für	
				Ersetzt durch	
Zust.	Änderungen	Datum	Name	Datum	Name
				Bearb. 07.12.2009	JSch
				Gepr.	
				Norm.	
				Allgemeintoleranzen nach DIN ISO 2768-mK	
				Schutzvermerk nach DIN 34 beachten!	

6 5 4 3 2 1